

TECHNICAL INSTALLATION MANUAL

UNDERGROUND OPERATOR FOR SWINGING GATES

COMPAS 2



WARNING!! Before installing, thoroughly read this manual that is an integral part of the pack

Our products if installed by qualified personnel capable to evaluate risks, comply with norms UNI EN 12453, EN 12445



The CE mark conforms to European directive
EEC 89/336 + 92/31 + 93/68 D.L. 04/12/1992 N. 476.

INDEX

	Pag.
PACKING CONTENTS	2
VIEW OF TYPICAL AUTOMATION AND NAMES OF COMPONENTS	3
TECHNICAL DATA.....	3
DIMENSIONS	4
TYPICAL CONNECTION AND CABLE SECTION.....	4
CONSIDERATIONS FOR INSTALLATION.....	5
INSTALLATION.....	5-6
TROUBLESHOOTING.....	7
SAFETY PRECAUTIONS	8

PACKING CONTENTS

1- UNDERGROUND OPERATOR



1- SIMPLE LEVER FOR WING ANCHORAGE



1- UNLOCKING KEY



1- CONDENSER (230VCA)

VIEW OF TYPICAL AUTOMATION AND NAMES OF COMPONENTS

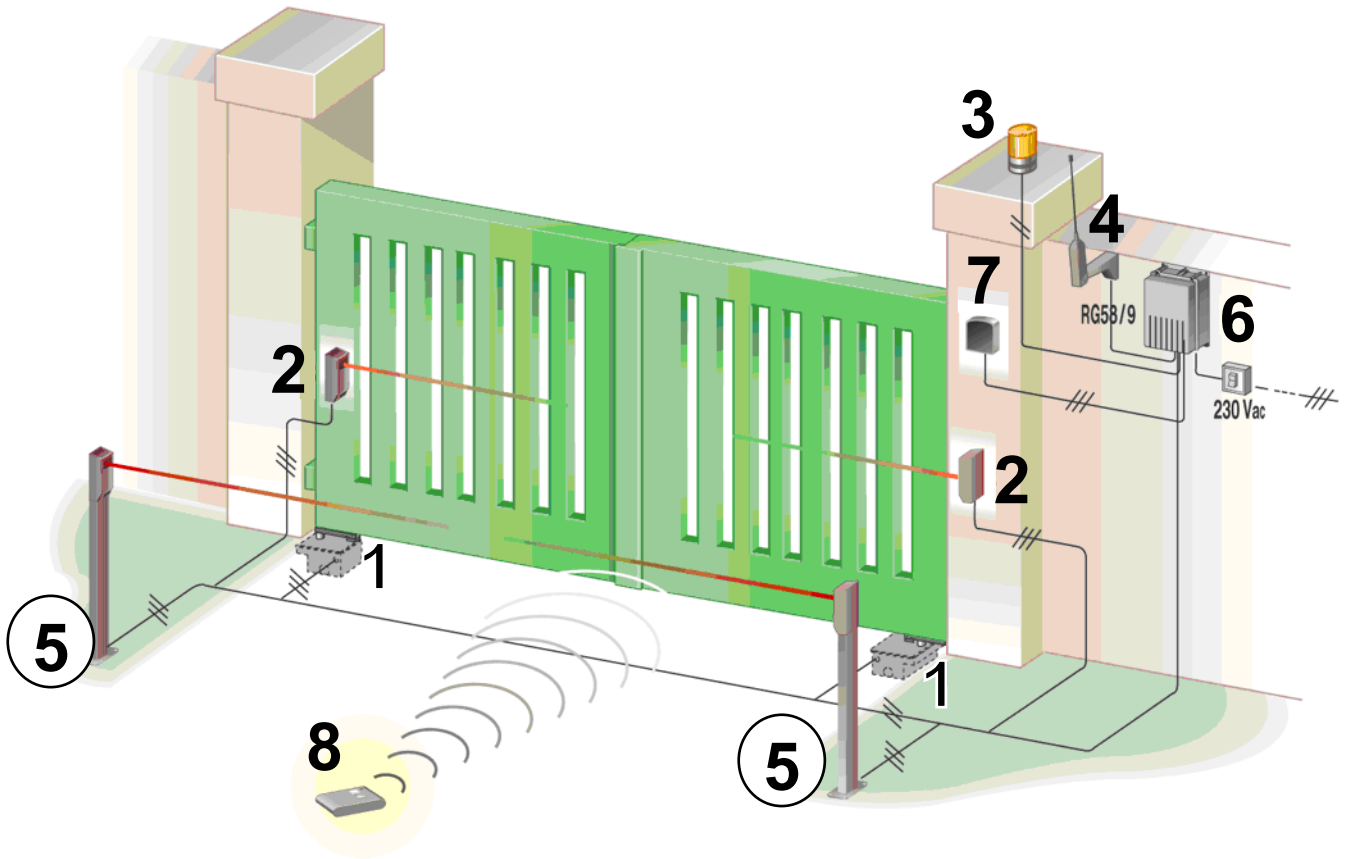

Optimal installation

- | | |
|---------------------------|----------------------------|
| 1- Operator | 5- Internal photocell |
| 2- External photocell | 6- Electronic control unit |
| 3- Flashing warning light | 7- Key-switch |
| 4- Antenna | 8- Remote control |

TECHNICAL DATA	24V	230V
	Max. weight of gate	250 Kg
Max. width of gate	2,50 mt	
Motors power supply	24Vdc	230 Vac
Motor power	50 W	250 W
Motor RPM	1800	1400
Condenser	/	16 µF
Mechanical unlock for emergency manoeuvre	Con Llave	
Working temperature	-20° C / +55° C	
weight	10 Kg	
Protection rating	IP 67	
Opening time 90°	15 sec	
Motor current input	2,0 A	1,4 A

DIMENSIONS

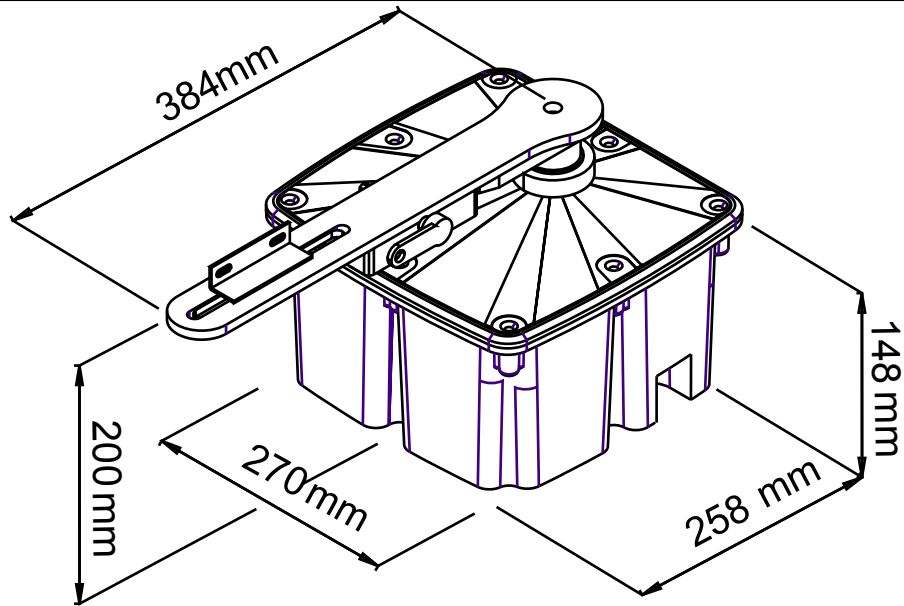

TYPICAL CONNECTION AND CABLE SECTION

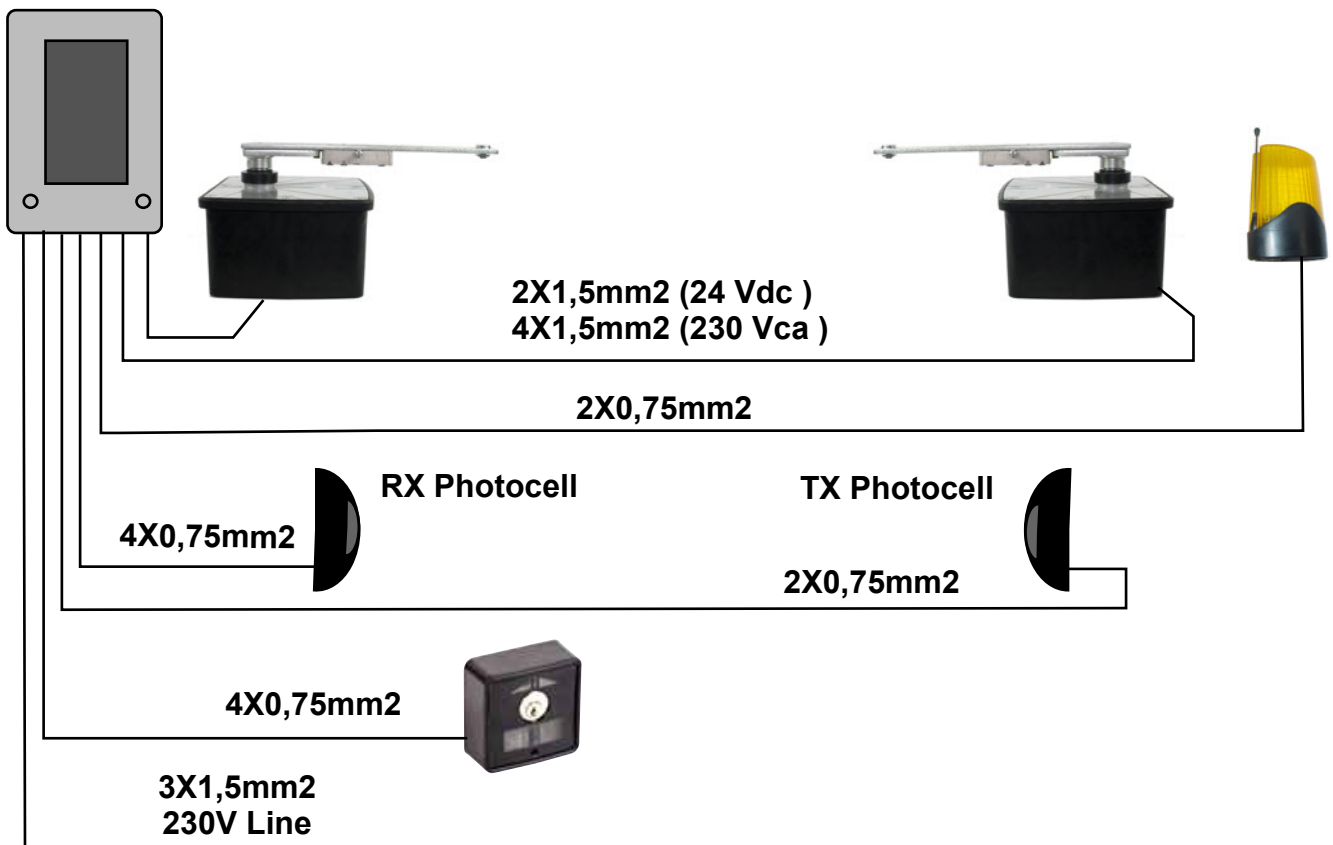

CONSIDERATIONS FOR INSTALLATION

- The installation and testing operations must be performed solely by qualified personnel in order to guarantee the proper and safe operation of the automatic gate.
- The company declines any responsibility for damage caused by incorrect installations due to incompetence and/or negligence.
- Before assembling the automatism, check that the gate is in perfect working order, hangs well on its hinges and is suitably lubricated. It must also comply with the safety standards in force in the country of installation.

INSTALLATION

Introductory note: Dig a hole big enough to hold the operator, calculate the required opening angle considering that the Compass operator can also be installed Out of Axis, insert the sheath for laying the power cable, and cement solidly.

GATE WING OPENING ANGLE

Establish the required opening angle opportunely positioning the opening locks for the shutters.

INSTALLATION PROCEDURE

Establish where the operator is to be installed

- Prepare the sheath for laying the power cable
- Execute the splice of the cable one watertight box

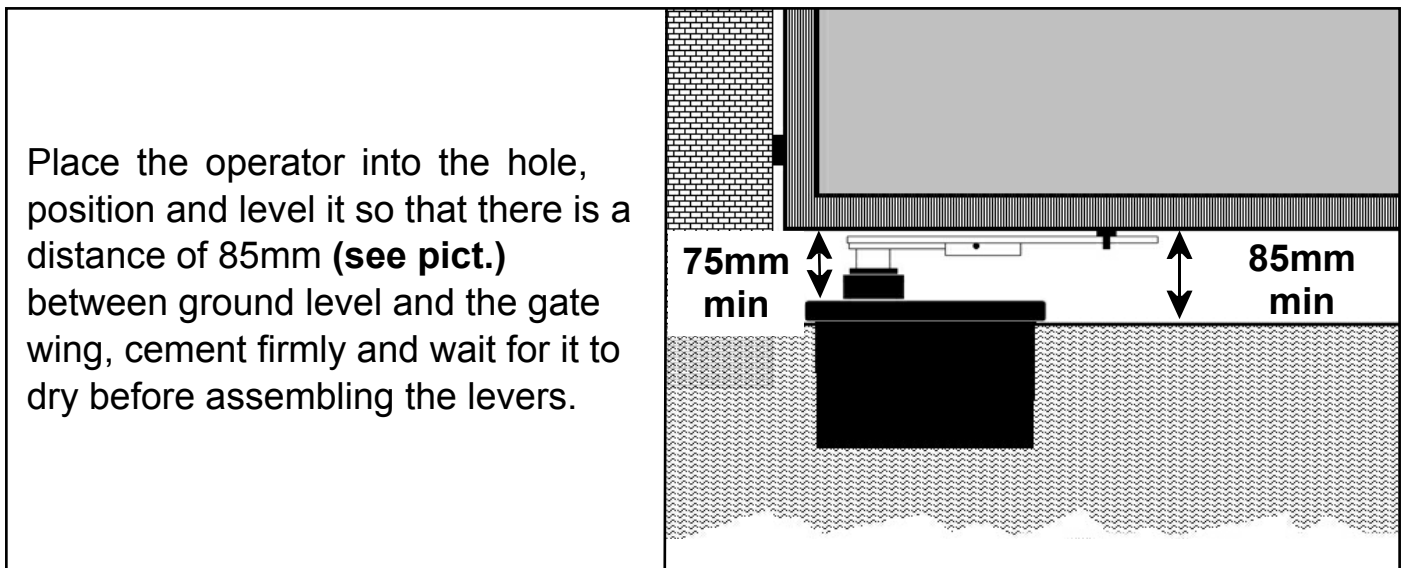
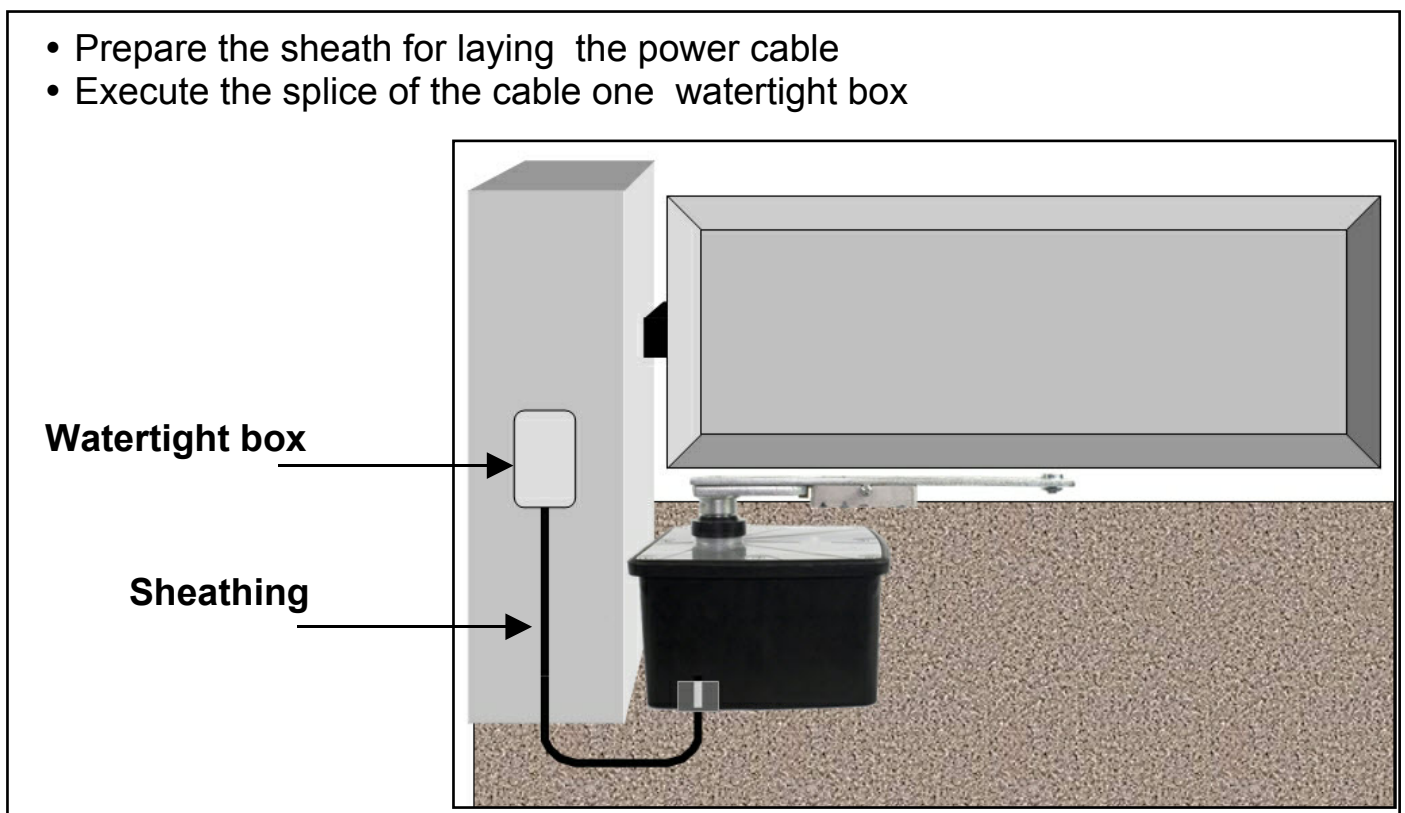

Insert and fasten the lever on the toothed pinion of the operator

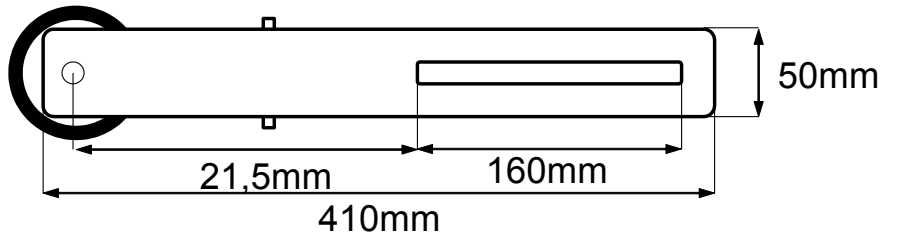

Fix the bracket to the gate, then to the lever with the seeger and washer.

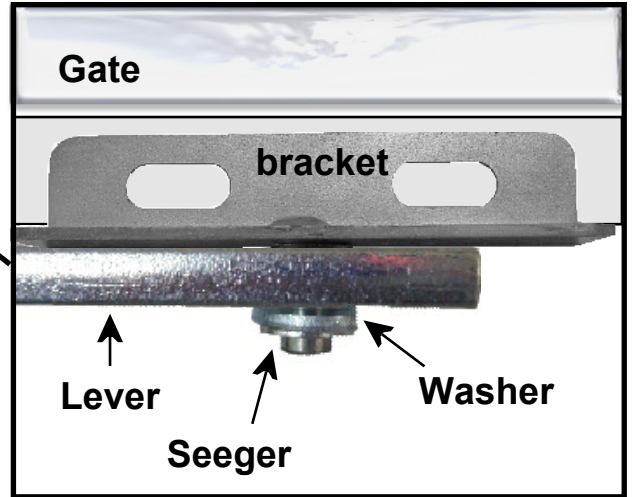
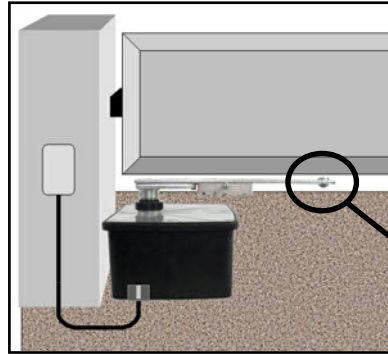

MECHANICAL END STOP (OPTIONAL)

It is possible to install the mechanical end stop either in opening or in closing setting the two bolts.

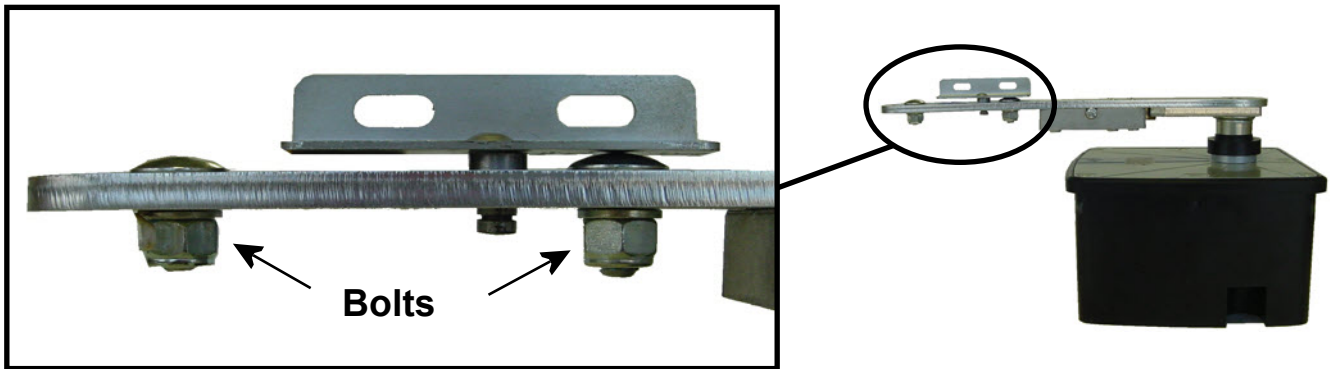

EMERGENCY RELEASE PROCEDURE

In order to release the swing of the gate you may insert and turn the key which is on the pivot of the anchoring lever motor reducer/gate

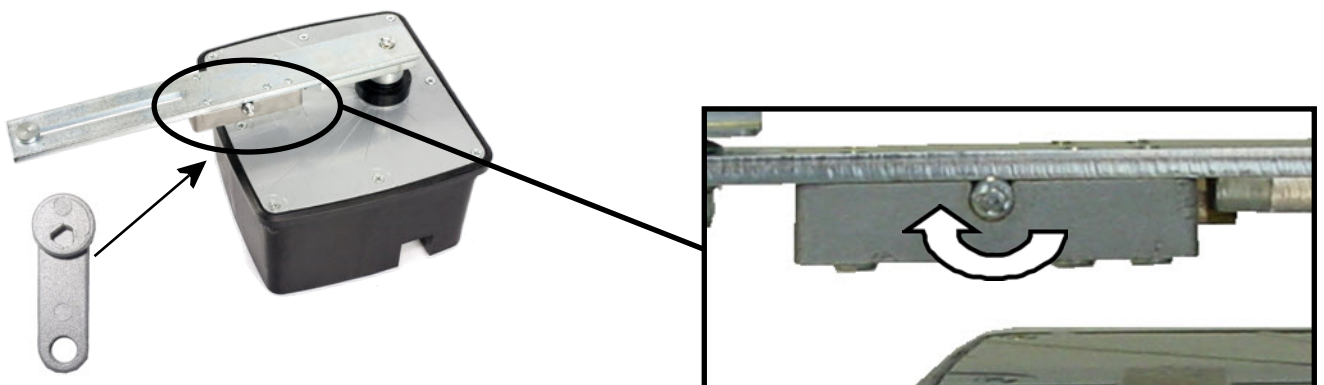

TROUBLESHOOTING

PROBLEM	PROBABLE CAUSE	SOLUTION
On giving a command with the remote control or with the key-switch, the gate doesn't open or the motor doesn't start	230 volt mains voltage absent	Check master switch
	Emergency STOP present	Check for any STOP selectors or commands. If not used, check jumper on STOP contact input on the control board
	Fuse blown	Replace with one of same value.
	Power cable of motor or motors not connected or faulty.	Connect the cable to appropriate terminal or replace.
	The photocell is not functioning or the beam is interrupted	Check the connection, remove any obstacle across the beam
On giving a command with the remote control, the gate doesn't open but works with the key command	The remote control has not been memorised or the battery is flat	Carry out the remote control learning procedure on the radio receiver or replace the battery with a new one..
The gate starts, but stops immediately	The force of the motor or motors is insufficient	Modify the value with the FORCE trimmer on the control unit
One wing opens and the other closes	The connection is not correct	Invert the connection of the cable of the motor which rotates in the wrong sense

N.B. - If the problem persists, contact your Retailer or the nearest Service Centre

SAFETY PRECAUTIONS

These warnings are an essential, integral part of the product and must be given to the user. They provide important indications on the installation, use and maintenance and must be read carefully. This form must be preserved and passed on to subsequent users of the system. The incorrect installation or improper use of the product may be dangerous.

INSTALLATION INSTRUCTIONS

- The installation must be performed by professionally skilled personnel and in compliance with current local, state, national and European legislation.
- Before beginning the installation, check the integrity of the product.
- The laying of cables, electrical connections and adjustments must be workmanlike performed.
- The packing materials (cardboard, plastic, polystyrene, etc.) are a potential hazard and should be disposed of correctly and not left within reach of children.
- Do not install the product in potentially explosive environments or environments disturbed by electromagnetic fields. The presence of inflammable gases or fumes is a grave danger to safety.
- Set up a safety device for overvoltage, a disconnecting and/or differential switch suitable for the product and conforming to current standards.
- The manufacturer declines any and all responsibility for product integrity, safety and operation in the event incompatible devices and/or components are installed.
- Solely original spare parts should be used for repairs and replacements.
- The installer must provide all the information relating to the operation, maintenance and use of the individual parts, components and system as a whole.

WARNINGS FOR THE USER

- Read the instructions and enclosed documentation carefully.
- The product must be used for the express purpose for which it was designed. Any other use is considered improper and therefore hazardous. In addition, the information given in this document and in the enclosed documentation may be subject to modifications without prior notice. It is given as an indication only for product application. The company declines any responsibility for the above.
- Keep products, devices, documentation and anything else provided out of reach of children. In the event of maintenance, cleaning, breakdown or faulty operation of the product, cut off the power and do not attempt to operate on the product. Contact solely the professionally skilled personnel responsible for these operations. Failure to adhere to the above indications may be dangerous.

The data and images are for guidance only

VDS reserves the right to change at any time characteristics of the products described in its sole discretion, without notice.



1095 Budapest, Mester u. 34.

Tel.: *218-5542, 215-9771, 215-7550,
216-7017, 216-7018 Fax: 218-5542

Mobil: 30 940-1970, 20 949-2688

1141 Budapest, Fogarasi út 77.

Tel.: *220-7940, 220-7814, 220-7959,
220-8881, 364-3428 Fax: 220-7940

Mobil: 30 531-5454, 30 939-9989

E-mail: delton@delton.hu Web: www.delton.hu

www.kaputnyitunk.hu